

39 Cubic Yard Self Contained Compactor (SC-3900)

39 Cubic Yard Self Contained Compactor

(Model SC-3900)

To request a Quote or to Purchase this product online:
3900-SC - [Click Here](#)

Leasing:
Monthly payment calculator - [Click Here](#)
For a printable application - [Click Here](#)

Rental Program:
For Rental information - [Click Here](#)



Self Contained Compactors are built for applications that require storage and removal of wet waste. Applications such as hotels, hospitals, food courts, restaurants and retail food stores all benefit from utilizing Self Contained Compactors.

SPECIFICATIONS

MFG Rating CU/YD	2
Wastec Rating CU/YD	1.16
Container Capacity	39
Clear Top Opening (L" x W")	42.5" x 57.5"
Ram Face (H" x W")	30" x 60"
Capacity Per Hour	175

PERFORMANCE

Cycle Time (Seconds)	33
Normal Force lbs	40,824
Normal Ram Face Pressure PSI	22.7
Ram Penetration	6.5"

HYDRAULIC / ELECTRICAL

Motor HP	10
Control Voltage	120 VAC
Pump GPM	11.5
Normal System Pressure PSI	1,800
Maximum System Pressure PSI	2,100
Cylinder Bore/Rod Diameter (Twin Cylinder)	4" / 2" x 2
Stroke	32"
Hydraulic Tank-Capacity Gallons	25

39 Cubic Yard Self Contained Compactor (SC-3900)

CONSTRUCTION	
Charge Box Sides	1/4"
Exterior Vertical / Horizontal Formed V	7 Ga
Charge Box Floor	1/2"
Ram Face	1/2"
Ram Bottom	3/8"
Ram Top	1/4"
Breaker Bar Structural Angle	6" x 8" x 3/4"
Longsills	6" x 2" x 1/4"
Understructure Floor	7 Ga
Container Sides	7 Ga
Top	10 Ga
Door	10 Ga

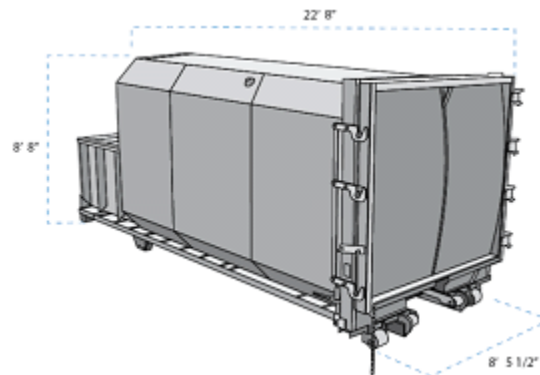
Dimension Diagram

- Continuous Product improvement is our policy. Therefore, in our efforts to provide products with the most up to date engineering and design, we reserve the right to change specifications without notice.
- Performance may vary depending upon application.
- Products must be installed and operated according to required standards, codes, regulations and safety procedures.