

Small Commercial Compactor (Model SSS-1001)

http://www.wastecare.com/Products-Services/Compactors/Trash_Compactors/Compactors_Commercial-Mobile/Compactors_Commercial_Main.htm



Small Commercial Compactor - Specifications & Dimensions

<i>(Approximate:)</i>	Small
Height	71"
Width	23"
Depth	25"
Loading Door	19" W x 16" H
Cube Capacity	3.3 cu. ft.
Reduction Ratio (up to)	up to 25: 1
Motor	3 / 4 HP
Ram Pressure (up to)	9,900 lbs.
Cycle Time	16 Seconds
Cylinder Size	2.5"
Electrical Power	115v / 230v
Circuit Size	115 V - 20 Amp 230 V - 20 Amp
Weight	675 lbs.
Full Cube Weight (up to)	up to 125 lbs.

Standard Compactor Features:

Stainless Steel throughout including Durable all Stainless Steel Cabinet.
Heavy Duty Cylinder
Swivel Locking Casters
Safety Lock Doors
Full Indicator Light & Buzzer
Locking Key Switch
Hydraulic Trash Ejector
Two Stage Hydraulic Pump.
Air Sanitizer
Built-In Bag Dispenser
Durable Inside Heavy Duty Plastic Container (2 piece design for easier handling)

Small Commercial Compactor Diagram:

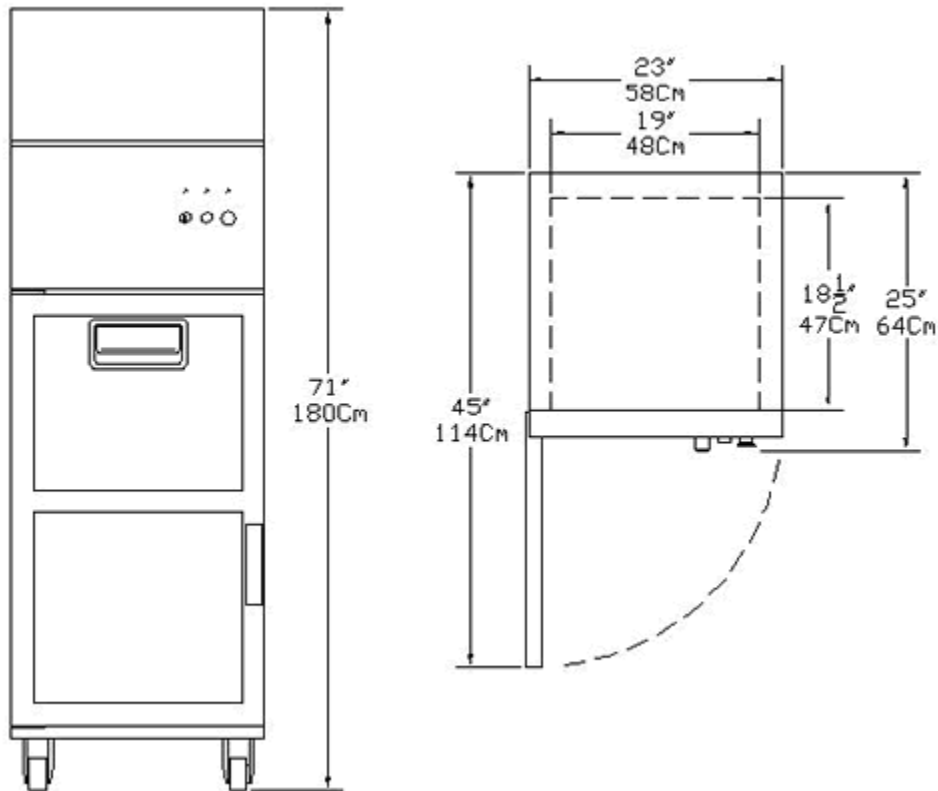

* **Note:** Specifications, Dimensions & other product details may vary slightly upon delivery due to continuous product progressions and improvement. If exactness is required on any item(s), confirm in writing before ordering. In our efforts to provide products with the most up to date engineering and design, we reserve the right to change specifications, dimensions and other product details without notice.

• Performance may vary depending upon application.

• Products must be installed and operated according to required standards, codes, regulations and safety procedures

WasteCare Corporation www.wastecare.com **888-200-4100**