

## Large Commercial Compactor (Model LSS-1001)

[http://www.wastecare.com/Products-Services/Compactors/Trash\\_Compactors/Compactors\\_Commercial\\_Mobile/Compactors\\_Commercial\\_Main.htm](http://www.wastecare.com/Products-Services/Compactors/Trash_Compactors/Compactors_Commercial_Mobile/Compactors_Commercial_Main.htm)



### Large Commercial Compactor - Specifications & Dimensions

<i>(Approximate:)</i>	Large
Height	78"
Width	40"
Depth	30"
Loading Door	36" W x 19" H
Cube Capacity	9 cu. ft.
Reduction Ratio (up to)	up to 25: 1
Motor	2 HP
Ram Pressure (up to)	25,150 lbs.
Cycle Time	25 Seconds
Cylinder Size	4"
Electrical Power	115v / 230v
Circuit Size	115 V - 30 Amp 230 V - 20 Amp
Weight	1,300 lbs.
Full Cube Weight (up to)	up to 350 lbs.

## Standard Compactor Features:

<b>Stainless Steel throughout including Durable all Stainless Steel Cabinet.</b>
<b>Heavy Duty Cylinder</b>
<b>Swivel Locking Casters</b>
<b>Safety Lock Doors</b>
<b>Full Indicator Light &amp; Buzzer</b>
<b>Locking Key Switch</b>
<b>Hydraulic Trash Ejector</b>
<b>Two Stage Hydraulic Pump.</b>
<b>Air Sanitizer</b>
<b>Built-In Bag Dispenser</b>
<b>Durable Inside Heavy Duty Plastic Container (2 piece design for easier handling)</b>

## Large Commercial Compactor Diagram:

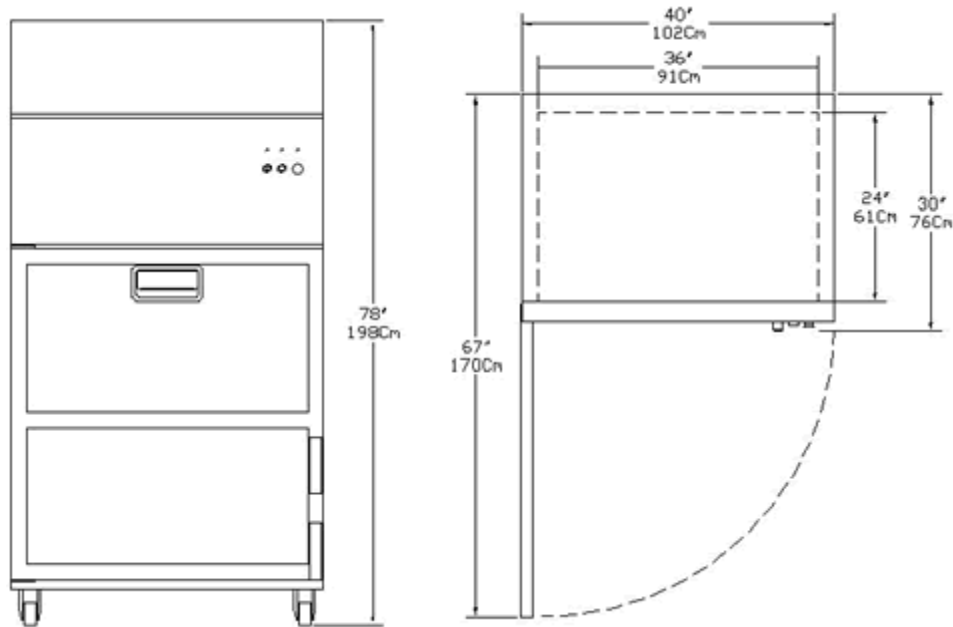

\* **Note:** Specifications, Dimensions & other product details may vary slightly upon delivery due to continuous product progressions and improvement. If exactness is required on any item(s), confirm in writing before ordering. In our efforts to provide products with the most up to date engineering and design, we reserve the right to change specifications, dimensions and other product details without notice.

• Performance may vary depending upon application.

• Products must be installed and operated according to required standards, codes, regulations and safety procedures

**WasteCare Corporation**    [www.wastecare.com](http://www.wastecare.com)    **888-200-4100**