

42" Compact Baler (Model 42-CVB)



Typical Baling Uses and/or Approximate Weights ('Up To' Weights)	
Material	Bale Weights (Approx)
Cardboard	175 Pounds
PET	
Aluminium Cans	
Shrink Wrap	
Note: Performance Rates, Bale Weights, and Bale Densities are subject to many factors such as Material Pre-Bale Densities, Feed rates, Moisture Content and other variables.	

42" Compact Vertical Baler Features
Fully UL Listed
Single Phase 115V / 230V
Key Operated Selector Switch
Non-Locking Casters
Loading Door / Platen Interlock
Twine Tie Package

42" Compact Vertical Baler – Main Options	
Description	Description
Wheel Chock – 1 Wheel Only	3 Phase 2 HP 208V / 230V Power Unit
Two Piece Unloading Door	3 Phase 2 HP 460V Power Unit
Hydraulic Filter Assembly	Twine For Bale Ties (2 Ball Pack)
Wire Guide Package – 4 Tie	

42" Compact Baler – Specifications & Dimensions

Small Compact 42" Vertical Baler Specifications	
Bale Size	22" x 42" x up to 30"
Bale Weight - Corrugated	Up to 175 pounds
Ram Pressure	@ 2000 25,133 pounds
Cycle Time	12 seconds
Cylinder	4" Bore 1.5" Rod 10" Stroke
Motor	2 HP, 1725 RPM, TEFC
Pump	Two Stage
Electrical Power	115/230 Volt, 1 Phase, 60Hz,
Bale Ejection	Manual Lever System
Bale Tying	Wire or Twine

Small Compact 42" Vertical Baler - Dimensions	
Loading Door Opening	20"x 42"
Unloading Door Height	38"
Overall Height	93"
Overall Depth	35"
Overall Width	50"
Depth with Door Open	80"
Width with Door Open	60"
Shipping Height	78"
Shipping Weight	1,475 Pounds
Required Operating Area	33.3 Square Feet

Meets ANSI Standards Z295.5 UL Approved Control Panel

* **Note:** Specifications, Dimensions & other product details may vary slightly upon delivery due to continuous product progressions and improvement. If exactness is required on any item(s), confirm in writing before ordering. In our efforts to provide products with the most up to date engineering and design, we reserve the right to change specifications, dimensions and other product details without notice.

- Performance may vary depending upon application.
- Products must be installed and operated according to required standards, codes, regulations and safety procedures.

WasteCare Corporation www.wastecare.com 888-200-4100

42" Compact Baler Diagram - Model 42-CVB

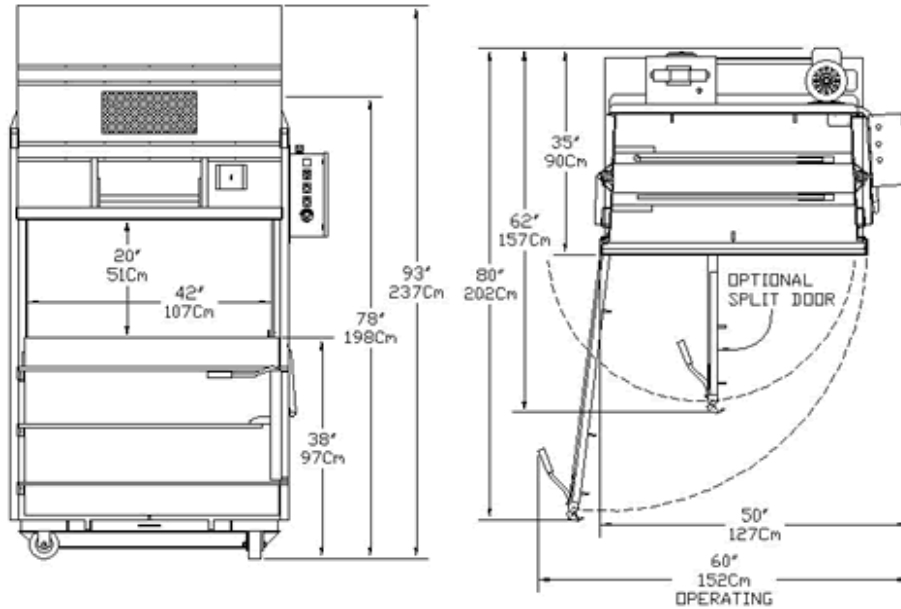

Note: Dimensions may be rounded (and unless indicated) do not include any recommended 'perimeter buffer'. If exactness is required, confirm in writing prior to ordering.

* **Note:** Specifications, Dimensions & other product details may vary slightly upon delivery due to continuous product progressions and improvement. If exactness is required on any item(s), confirm in writing before ordering. In our efforts to provide products with the most up to date engineering and design, we reserve the right to change specifications, dimensions and other product details without notice.

- Performance may vary depending upon application.
- Products must be installed and operated according to required standards, codes, regulations and safety procedures

WasteCare Corporation www.wastecare.com **888-200-4100**